

**Application for registration of a unit for manufacture of
Plastic Carry Bags & Containers**

From

M/s _____

To

The Environmental Engineer,
Punjab Pollution Control Board,
Regional Office,

Sir,

I/We hereby apply for registration under rule 10 of the plastics manufacture, sale and usage rules, 1999 as amended in 2003.

PART - A		
GENERAL		
1. (a)	Name of the unit and location of activity	
(b)	Address of the unit	
(c)	Registration required for manufacture of: (i) Carry bag virgin (ii) Carry bag recycled (iii) Containers virgin (iv) Container recycled	
(d)	Manufacturing capacity	
(e)	In case of renewal of Registration, previous registration no. & date	
2. (a)	Is the unit registered with DCSSI or Department of Industries of the State Government/ Union Territory/ Administration	
(b)	If yes, attach a copy	
3. (a)	Total capital invested on the project	
(b)	Year of commencement of production	
4. (a)	List and quantum of products and bye products.	
(b)	List and quantum of raw materials used	
5.	Furnish a flow diagram of manufacturing process showing input and output in terms of	

	products and waste generated including for captive power generation and de-moralized water.	
6.	Minimum sizes of carry bags to be manufactured. (in any case it should not be less than 8"x12")	
7.	Status of Compliance with rules 5, 6, 7 and 8	
PART – B		
PERTAINING TO LIQUID EFFLUENT AND GASEOUS EMISSIONS		
8.	(a) Does the unit have a valid consent under the Water (Prevention & Control of Pollution) Act, 1974 (6 of 1974)	
	(b) Does the unit have a valid consent under the Air (Prevention & Control of Pollution) Act, 1981 (14 of 1981) If yes, attach a copy)	
PART – C		
PERTAINING TO WASTE		
9.	Solid Wastes: (a) Total quantum of generation (b) Mode of storage within the plant (c) Provision made for disposal	

Place :

Date :

Signature of Applicant

Designation

ANNEXURE

(See Rule 2(b))

Shapes of Bags

Figure I

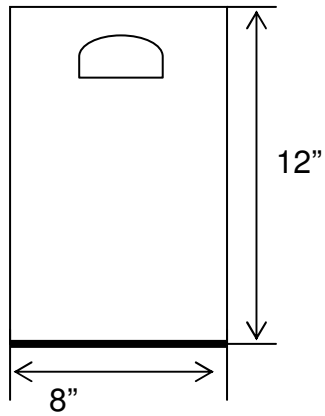

"D" Punched Bag

Figure II

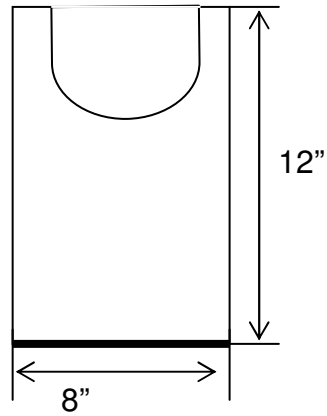

Vest Type Bag

